

Art.-Number: 701109

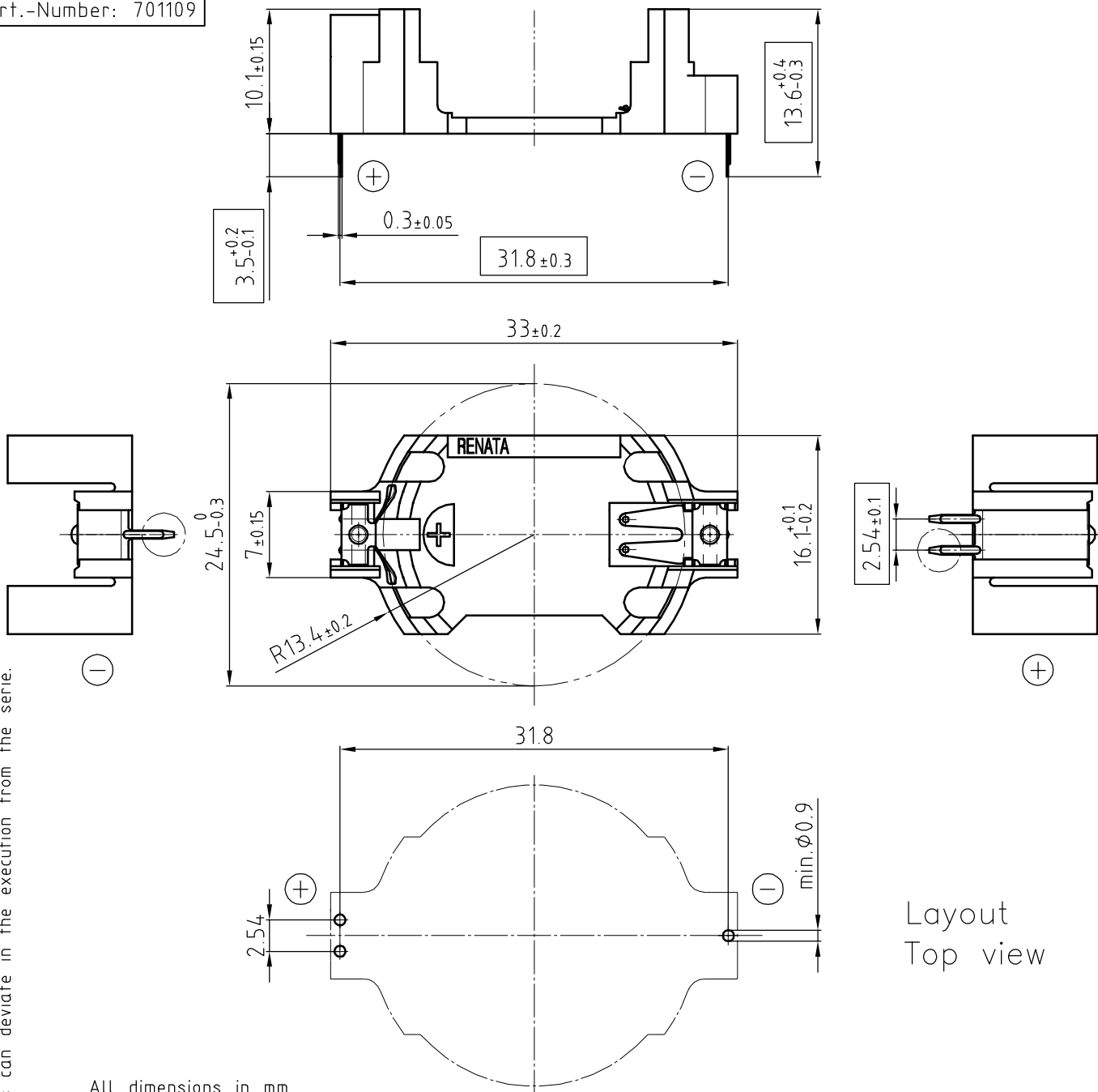

Layout
Top view

Samples can deviate in the execution from the serie.

- Dimensions and tolerances can be specified only after the testing of the devices for the mass production definitely

All dimensions in mm

Holder material : heat resistant, glass-fiber reinforced LCP

Battery contacts : spring stainless steel 301 nickel plated throughout

Solder contacts : spring stainless steel 301 solder area tin-plated throughout, min. thickness 5um

All framed values will be used for dimension checking !

The Products of Renata SA are neither designed nor authorized for use in certain areas of application of environment.

For further details we refer to our webpage www.renata.com/downloads/restriction_of_use

Rev.	①	10.09.07	Mci	Rev.	④	27.08.19	PWU		Customer's Approval		
Rev.	②	02.11.07	SRI	Rev.	○				Date		
Rev.	③	18.09.10	Wu Ping	Rev.	○				Signature		
Title:								Scale	Drawn	21.01.05	SRI
HU2477N-LF								2:1	Checked		
									Approved		

renata batteries

CH-4452 Itingen
Switzerland

3.8754.4-4